



“Top technology for sound excellence”

IBIZA LA 212 A

User manual

This manual has been designed to help IBIZA LA 212 A system users from Pro DG Systems to its correctly use and understand its benefits and versatility.

Before using the product, carefully read “Precautions” section of this manual (pages 4 - 5). Please keep this document in a safe place for future reference.



Before flying the system, carefully read “Safety instructions” subsection, located in “Flight hardware” section (pages 35 - 36).

The information included in this document may be changed without prior notice. To stay up to date with the latest version of this document, we recommend that you periodically consult Pro DG Systems website.

When reselling this product, give this document to the new owner. If you supply Pro DG Systems products, please inform your customers about this document.

Index

Precautions	4 - 5
Warranty	5
Declaration of conformity	6
Introduction	
- Description	7 - 8 - 9
- Technical datasheet	9 - 10
- Architectural specifications	10
User guide	
- First steps	11
- Troubleshooting	12 - 13
Components	
- Speakers	14 - 15 - 16
- Compression driver	17 - 19
- Horn	19

Amplifier	20
DSP - Software <i>ProDGnet</i>	
- Description	21
- Usage guide in PC	22 to 31
- Selecting presets in the unit itself	32 - 33
- Factory presets included in the unit	34
Flight hardware	
- Safety instructions	35 - 36
- Components	36 - 37 - 38
- How to fly the system up	39 - 40
- Stack mode usage	41
Ease Focus prediction software	42
Accessories	43

Precautions

Please read, keep and follow all safety and use instructions.

Important Safety Instructions.

1. Heed all warnings.
2. Do not overload the box to avoid damage to the speakers.
3. Do not use this product near water. If the box is used outdoors, make sure that no humidity can enter the box.
4. Clean only with a dry cloth.
5. Do not block any ventilation openings. Install in accordance with the manufacturer's instructions.
6. Do not install near any heat sources such as radiators, heat registers, stoves or similar (including amplifiers).
7. Do not defeat the safety purpose of the polarized or grounding-type plug. A polarized plug has two blades with one wider than the other. A grounding-type plug has two blades and a third grounding prong. The wider blade or third prong is provided for your safety. If the provided plug does not fit in your outlet, consult an electrician for replacement of the obsolete outlet.
8. Protect the power cord from being walked on or pinched, particularly at plugs, convenience receptacles, and the point where it exits from this product.
9. Only use attachments/accessories specified by the manufacturer.
-  10. Use only with the cart, stand, tripod, bracket or table specified by the manufacturer or sold with the product. When a cart is used, use caution when moving the cart/product combination to avoid injury from tip-over.
11. Unplug this product during lightning storms or when unused for long periods of time.
12. Refer all servicing to qualified personnel. Servicing is required when the product has been damaged in any way such as power-supply cord or plug is damaged, liquid has been spilled or objects have fallen into the product, the product has been exposed to rain or moisture, does not operate normally, or has been dropped.

WARNINGS / CAUTIONS:



This symbol on the product means there is uninsulated, dangerous voltage within the product enclosure that may present a risk of electrical shock.



This symbol on the product means there are important operating and maintenance instructions in this guide.



This symbol indicates that the product cannot be treated as ordinary household waste, it must be deposited at the corresponding collection point for electrical and electronic equipment.



This product contains magnetic material. Consult your doctor on whether this might affect your implantable medical device.



Contains small parts which may be a choking hazard. Not suitable for children under age 3.

Warranty

All the Pro DG Systems products have a 24-month warranty period, which begins from the invoice date of the first purchase.

Consult everything relevant to the warranty conditions at Pro DG Systems website: <https://prodgsystems.com/20-vc-warranty.html>

Or via email at: info@prodgsystems.com

Declaration of conformity



Pro DG Systems declares that the product with reference **IBIZA LA 212 A** complies with the objectives expressed in the following **European Directives**:

- Low voltage 2014/35/UE.
- Electromagnetic compatibility 2014/30/UE.
- RoHS 2011/65/UE. About restrictions on the use of certain dangerous substances in electrical and electronic equipment.
- RAEE / WEEE 2012/19/UE. About waste electrical and electronic equipment.
- General Product Safety 2023/988/UE.

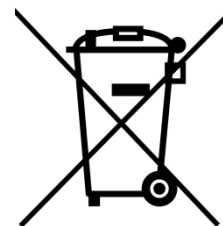

And it complies with the following **European Harmonized Standards**:

- EN 60065:2014. Audio, video and analog electronic devices.
- EN 55032:2012. Electromagnetic compatibility of multimedia equipment. Part 1: emission requirements.
- EN 55103-2:2009. Electromagnetic compatibility. Part 2 Immunity.

This declaration is available for request by email: info@prodgsystems.com

Or to be downloaded from the website: www.prodgsystems.com

Description

IBIZA LA 212 A is one of the Line Array systems from the new **IBIZA Series**.

The new IBIZA Series represents the natural evolution of the previous and prestigious GT and GTA series from **Pro DG Systems**, now with a completely modernized appearance, with much more power and less weight thanks to the incorporation of new state-of-the-art Beyma neodymium components.

Designed and manufactured in Spain, the new IBIZA LA 212 A is the most powerful self-powered three-way Line Array system in its range on the market.

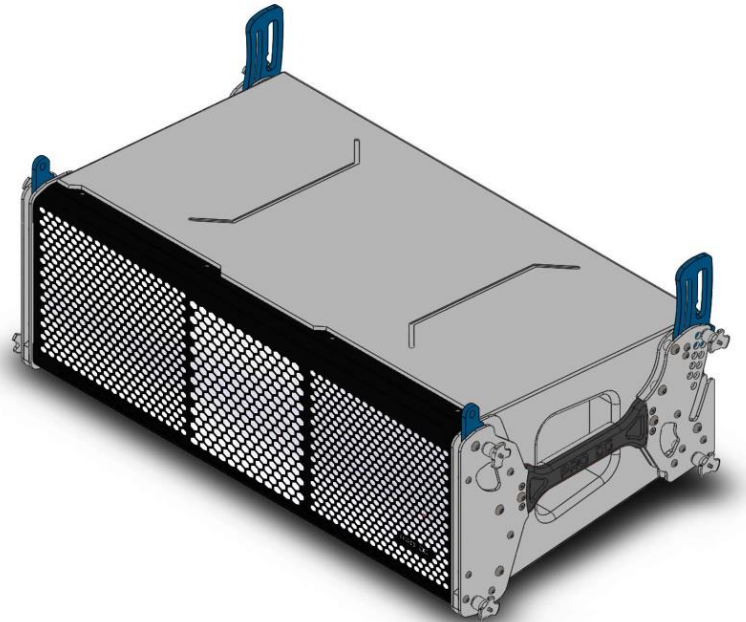

Equipped with two 12" Beyma speakers in a tuned enclosure, responsible for reproducing LF and MF. The HF section features one 1/4" Beyma compression driver coupled to a waveguide.

The transducer configuration generates a symmetrical and horizontal dispersion of 90° without secondary lobes in the frequency range.

IBIZA LA 212 A has a **new state-of-the-art Class-D amplifier module and own DSP**, very intuitive to use for easy handling and absolute control. The included amplifier has been designed to, in addition to amplifying the unit itself, amplify another passive unit (IBIZA LA 212 P) in slave mode, thanks to the incorporation of one channel with 2500 W RMS for LF + one channel with 1500 W RMS for MF + 1 channel with 500 W RMS for HF.

It incorporates a switching power supply and a limiter system to guarantee the protection of both the amplifier and the other components as well. Includes factory presets.



Remote processing, control and management are carried out through **ProDGnet** software. **ProDGnet** software allows an instantaneous and intuitive view of the status of all systems, as well as absolute control of the different parameters individually (unit by unit).

Ease Focus prediction software is available.

At Pro DG Systems we know the importance for professionals of having a flexible, easily configurable system that guarantees maximum sound performance without the cost of external processors or additional wiring.

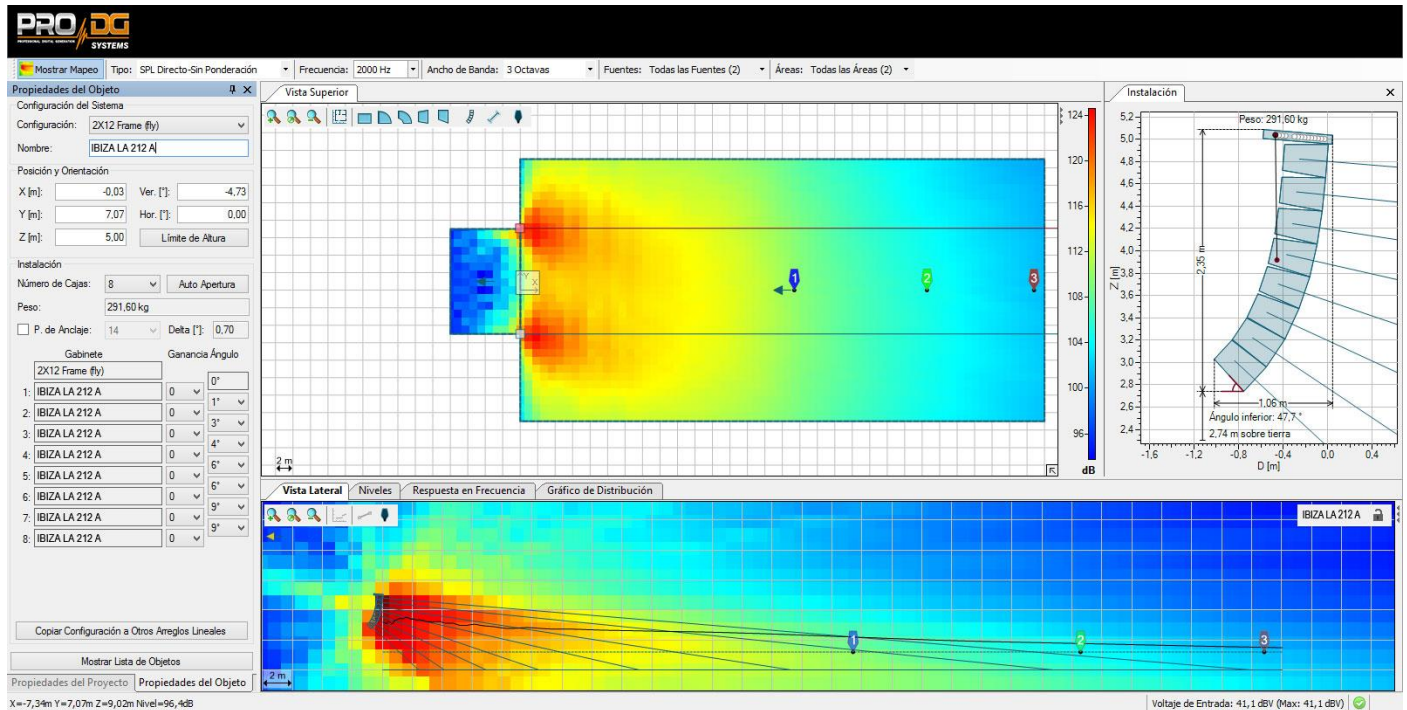

The joint use of *ProDGnet* processing software and Ease Focus prediction software allows you to achieve this objective in seconds, achieving:

- Remote SPL level control.
- Frequency response uniformity for the entire public.
- Digital direction of sound projection in listening areas.
- Reduction of the sound pressure level in areas that should be avoided, such as the stage, walls, or unused balconies.
- Simplification and streamlining of assembly times.

The construction of the IBIZA LA 212 A system is made of birch plywood using CNC machining, with a special polyurea finish resistant to impacts and inclement weather.

Its front part is protected by a robust metal grille and acoustic foam.

The **flight hardware** design of IBIZA LA 212 A system is quick and intuitive to use. The fly bar also allows the use of several units in stack format.

Easy to transport thanks to its compact and ergonomic design, offering a pleasant visual impact too. IBIZA LA 212 A has all the necessary accessories for transport and complete wiring ready to plug in and work.

The perfect solution as main PA at outdoor events or permanent installation. Ideal for working in live concerts, theaters, coverage under amphitheaters, places of worship, corporate applications and all types of events where high performance and versatility are necessary.

Technical datasheet

IBIZA LA 212 A	
Power handling	1800 W RMS / 3600 W program / 7200 W peak.
Maximum SPL Calculation	1m / 134 dB continuous / 137 dB program / 140 dB peak.
Nominal impedance	8 Ohm.
Frequency range	60 - 20000 Hz.
Dispersion angle	90° horizontal. Vertical dependent on distribution.
LF Component	One Beyma 12" speaker. Neodymium. 1000 W RMS.
MF Component	One Beyma 12" speaker. Neodymium. 700 W RMS.
HF Component	One Beyma 1/4" compression driver. Neodymium. 100 W RMS.
Frequency cut-off for LF*	Without subwoofer: 60 Hz Linkwitz-riley 24 filter - 250 Hz Linkwitz-riley 24 filter. With subwoofer: 90 Hz Linkwitz-riley 24 filter - 250 Hz Linkwitz-riley 24 filter.
Frequency cut-off for MF *	250 Hz Linkwitz-riley 24 filter - 1200 Hz Linkwitz-riley 24 filter.
Frequency cut-off for HF *	1200 Hz Linkwitz-riley 24 filter - 18 kHz Linkwitz-riley 24 filter.
Frequency cut-off for subwoofer *	Up to 90 Hz. Linkwitz-riley 24 filter.
Amplifier	State-of-the-art Class-D. 1 x 2500 W RMS for LF + 1 x 1500 for MF+ 1 x 500 W RMS for HF. Surge protection up to 265 V AC, output protection against overload, clip, limiter. Input type: balanced. Input impedance: 20000 ohms. Input sensitivity: 6.2 V (+18 dBu).

DSP	24 Bit / 96 KHz. 6 factory presets with on-screen selection button.
Pro DG net	1 RS485 input + 1 output link RS485 for network control of the entire system.
Connectors	1 x XLR female (input signal), 1x XLR male (output link). 1 x Speakon output for passive unit IBIZA LA 212 P. PowerCON NAC3FCB (current supply).
Controls	On / off switch and master volume. Preset selector cursor.
Power supply	AC 90~265V - 50 / 60HZ.
Construction	Birch plywood using CNC machining. 2mm thick perforated steel front grille, with oven-dried black electrostatic powder paint finish. Includes acoustic foam.
Paint	Special polyurea finish resistant to impacts and inclement weather. Black color (standard).
Dimensions (height x width x depth)	352 x 966 x 468 mm (13,86 x 38,03 x 18,43 in).
Weight	45,5 Kg (100,31 lbs) net / 48,5 Kg (106,92 lbs) with packaging.

* Disrespect the suggested frequency cuts-off on the different ways may cause components breakage.

Architectural specifications

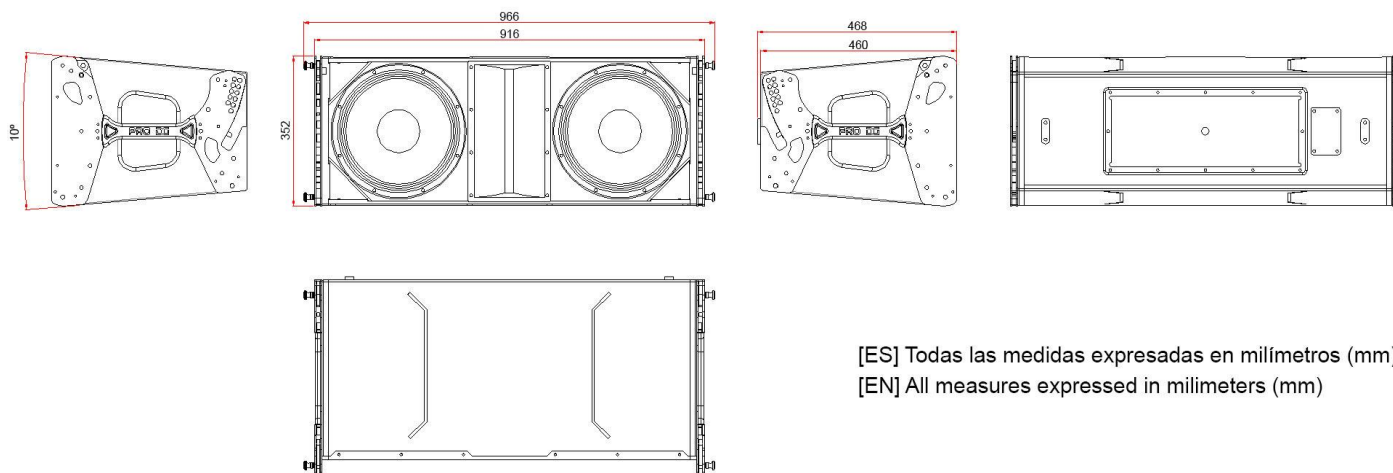

[ES] Todas las medidas expresadas en milímetros (mm)
[EN] All measures expressed in millimeters (mm)

User guide. First steps

Turning On / Off

Turning on any sound system must be done from back to front. Turn on sources such as CD players first, then the mixer, then the processors, and finally the self-powered loudspeakers. If you have several self-powered loudspeakers, it is advisable to turn them on sequentially one by one.

When turning off the sound system, follow the reverse process, turning off the self-powered loudspeakers before any other element of the system.

Disconnect the device using the mains plug. Both the power connector and the plug must always be accessible and must never be covered or blocked.

To disconnect the power, remove the Powercom type cable from the power connector located on the equipment amplifier, perform this operation on all loudspeakers.

Important: do not unplug the computer when music is playing.

Limiter

IBIZA LA 212 A amplifier has a limiter system to protect the equipment.

An excessive level makes the equipment sound bad, causing hearing fatigue, with consequent damage to your health.

Equalization

This system does not need additional equalizers. In any case, values higher than +3dB are not recommended.

Remote control and processing are carried out through the **ProDGnet** software (see page 21 for more information).

Overheating

The amplifier has a cooling system by incorporating an aluminum heatsink plate and forced ventilation. In case of overheating the amplifier will mute to protect itself. In most cases it will be enough to let the unit cool down for it to work properly again.

You must ensure that the ventilation grilles are free of dust and dirt, as well as preventing their obstruction.

User guide. Troubleshooting

Problem	Cause	Solution
The unit does not sound.	<ol style="list-style-type: none"> 1. The signal source is not sending a signal over the cable. 2. Defective cable. 	<ol style="list-style-type: none"> 1. Check the mixer output indicator to see if the signal is being sent. 2. Make sure the cables are connected correctly. If so; use another cable.
The unit does not sound at its maximum level.	<ol style="list-style-type: none"> 1. The mixer or signal source has insufficient output. 2. Possible overheating of the unit. 	<ol style="list-style-type: none"> 1. If you use a mixer, be sure to use balanced output if it has one. Use a mixer or signal source with a higher output level. 2. Lower the master level of the table.
Distorted sound signal.	The mixer or other signal is distorting.	Lower the overall mixer output level or channel gain. Check that the signal source is ok.
Distorted and very loud sound signal.	The system is being overloaded with too much input signal and has reached maximum power.	Lower the mixer output level.
Noise when the unit is connected to a mixer.	<ol style="list-style-type: none"> 1. Probably the output has unbalanced output. Poorly constructed unbalanced to balanced cables are being used. 2. The connections to the electrical network are not correct. 3. The signal cable is too long or too close to the AC line. 	<ol style="list-style-type: none"> 1. Check output and replace wiring. 2. Plug the mixer and powered box into the same outlet. 3. Use a signal cable as short as possible and avoid it being too close to the AC power cable.

<p>Noise or buzz when light controls are used in the same environment.</p>	<ol style="list-style-type: none"> 1. The sound system is connected to the same phase than the lights. 2. The sound cables are too close to the light cables. 	<ol style="list-style-type: none"> 1. Connect the sound system and lighting system to different phases. Request the help of an electrician. 2. Aleje los cables de audio de los cables de luces.
<p>The system does not turn on even though the power cable is correctly connected, both to the network and to the box.</p>	<ol style="list-style-type: none"> 1. Defective cable. 2. Internal fuse blown. 	<ol style="list-style-type: none"> 1. Check the cables, connectors and power outlet with a tester or multimeter. 3. Contact your Pro DG Systems distributor or authorized professional to perform the repair.



If you have any technical problem or questions about Pro DG Systems products; contact our technical support department at: sat@prodgsystems.com

Speakers

IBIZA LA 212 A has two 12" Beyma speakers with neodymium magnet, one of them in charge of reproducing low frequencies and another one for medium frequencies.

Speaker for LF - main characteristics
Power handling of 1000 W RMS / 2000 W program
Forced air convection circuit
Optimized neodymium magnetic circuit
4" DUO technology moving coil
Weather resistant cone with treatment on both sides
5,4 Kg weight (per unit)
Optimized for great bass performance

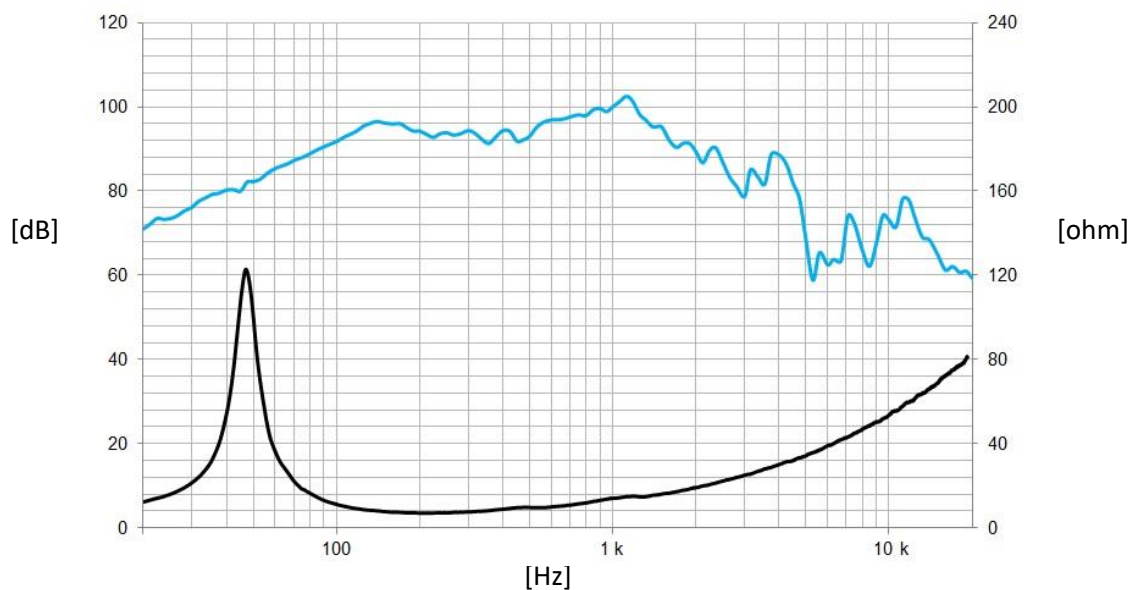

Frequency response measured with a speaker placed on an infinite baffle in an anechoic chamber, 1 W @ 1 m.

Speaker for LF - architectural

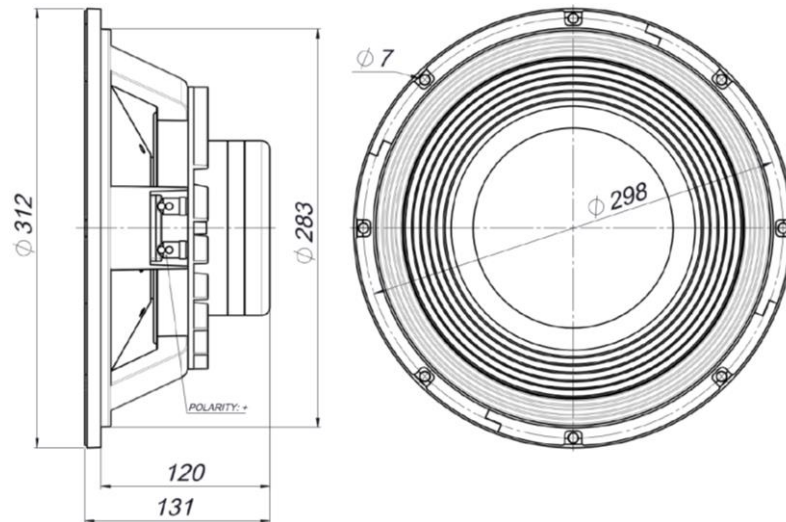

Speaker for MF - main characteristics

Power handling of 700 W RMS / 1400 W program

Exclusive cooling system with Malt Cross technology *

Optimized neodymium magnetic circuit

3" DUO Double Layer Input / Output Copper Voice Coil

Aluminum demodulator ring

Weather resistant cone with treatment on both sides

3,7 Kg weight (per unit)

Optimized to deliver great LF and MF range performance



* **Malt Cross** technology allows the speaker to handle higher powers with a given coil diameter, reducing weight and increasing sensitivity, while maintaining a total output SPL equivalent to a bigger and heavier speaker.

Malt Cross technology is an internal forced convection circuit that allows the working temperature of the voice coil to be reduced and, likewise, acts as a demodulator ring, linearizing the inductance of the transducer

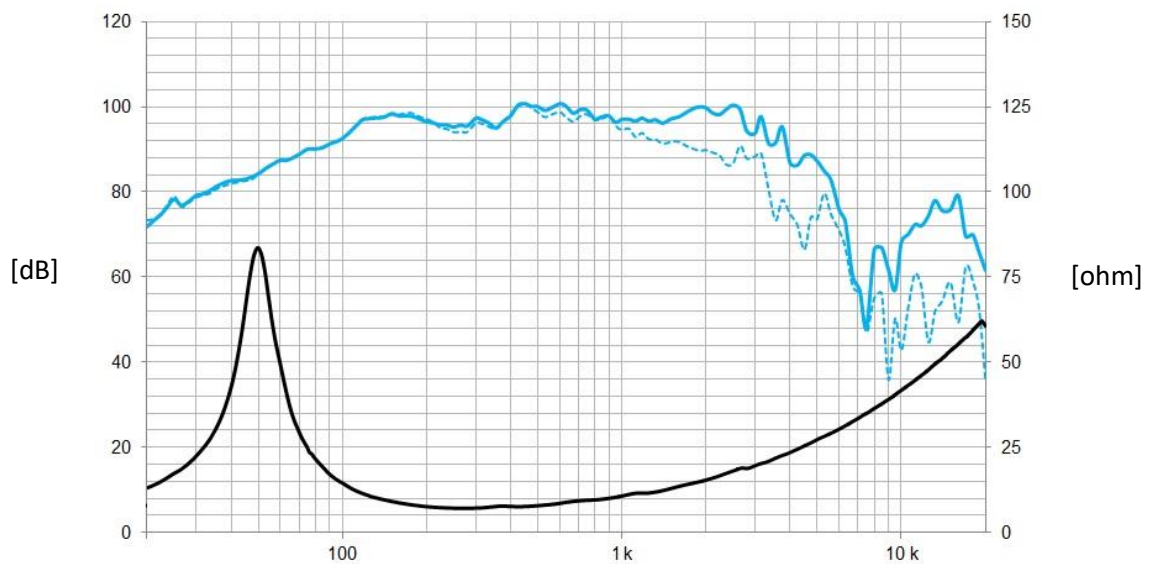

Frequency response measured with a speaker placed on an infinite baffle in an anechoic chamber, 1 W @ 1 m.

— On-axis frequency response.

- - - Frequency response 45° off-axis.

Speaker for MF - architectural

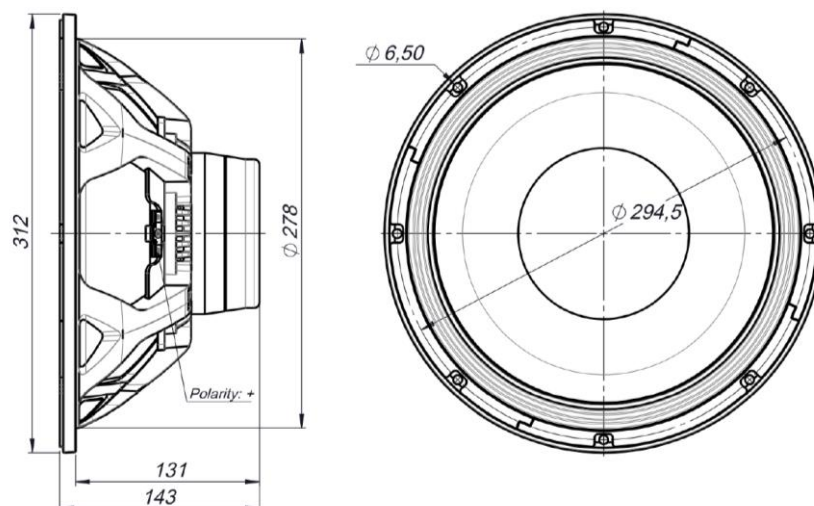

Compression driver

The HF section of the IBIZA LA 212 A has one 1/4" Beyma compression driver with neodymium magnet, in charge of reproducing high frequencies.



Main characteristics
Power handling of 100 W RMS / 200 W program above 1.2 kHz
Deplocex technology for improved thermal dissipation, low power compression losses and high power handling
2.5" (63,5mm) Copper Clad Aluminum Coil with Nomex Former
Exclusive titanium dome design, optimized for linear and extended response with minimized resonances
Patented metal alloy phase connector design with optimized geometry and improved assembly design
High quality optimized neodymium magnetic circuit
1,8 Kg weight (per unit)
Aluminum cover



The sophisticated titanium diaphragm features a mathematically optimized geometric pattern that improves system linearity and efficiency while eliminating unwanted resonances.

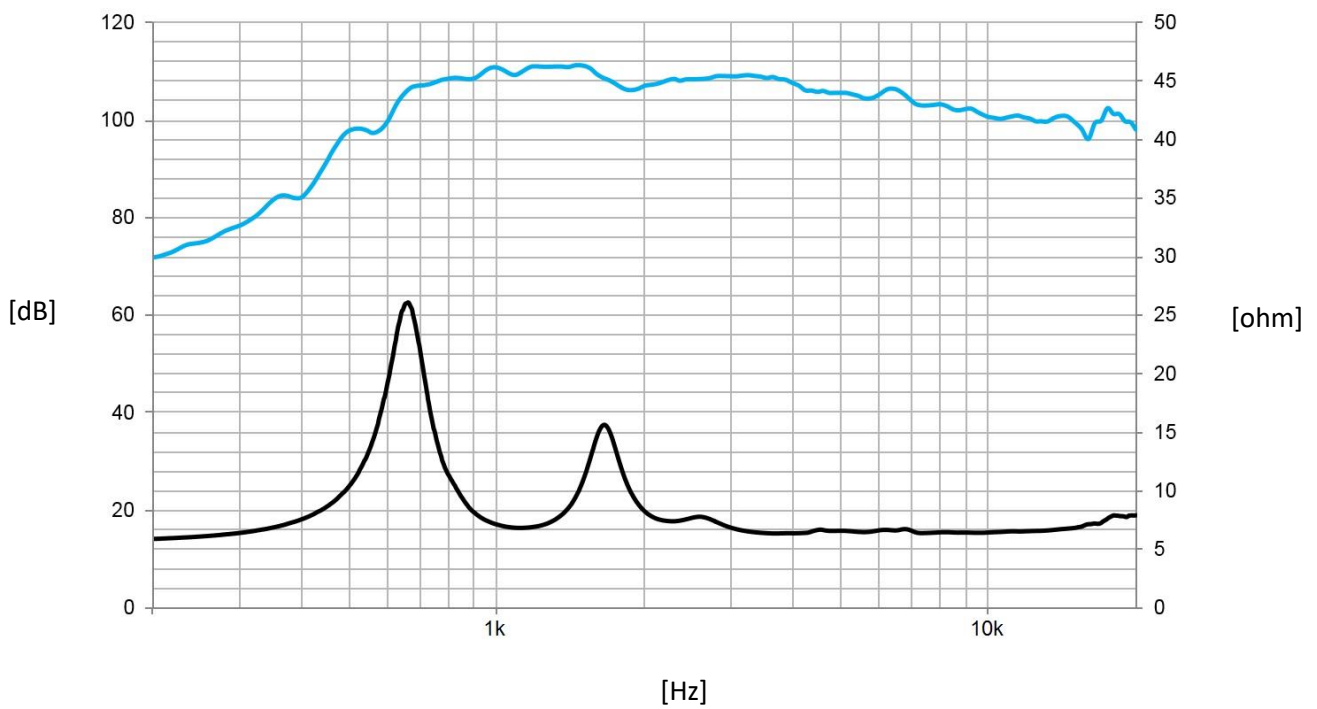

Frequency response measured on axis coupled to the IBIZA LA 212 A horn in an anechoic chamber, 1 W @ 1 m.

Architectural

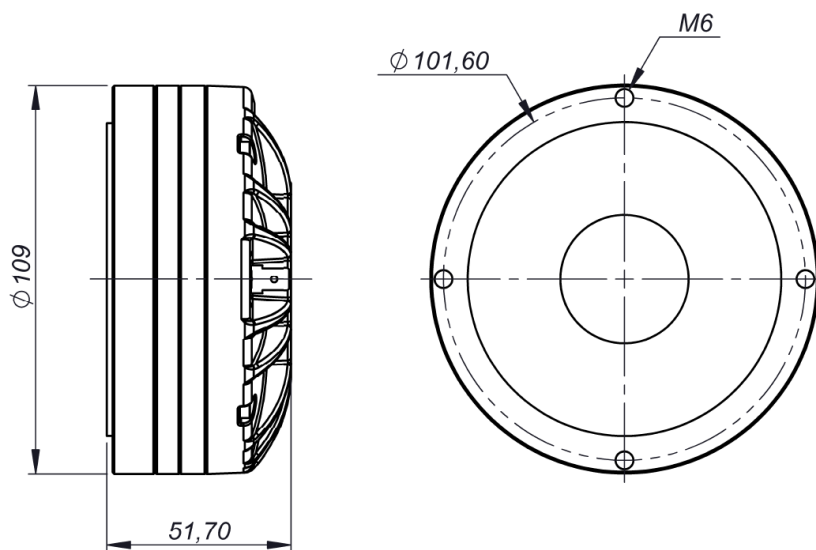

Horn

The compression driver of the IBIZA LA 212 A is coupled to a horn, specifically designed to achieve maximum performance and acoustic quality in high frequencies.



Made of fiberglass (BMC) and polyurethane (PU2). The combination of both materials allows obtaining a horn with great resistance and low weight, also providing a perfect blend between medium and high frequencies.

Measures (height x width x depth):
330 x 195 x 215 mm (12,99 x 7,68 x 8,47 in)

DSP. ProDGnet

Remote processing, control and management are carried out through **ProDGnet** software.



ProDGnet software allows an instantaneous and intuitive view of the status of all systems, as well as absolute control of the different parameters individually (unit by unit).

To operate with *ProDGnet* software from your PC you will only need:

- Download ProDGnet software at Pro DG Systems website (section “Support” > “Software”): <https://prodgsystems.com/24-vc-software.html>

Easy to download, all the necessary drivers for installation are included.

Important: the software is currently available for any version of Windows (32 and 64 bits).

- Acquire *ProDGnet* interface (optional), to connect the DSP module housed in the amplifier with your PC. To purchase *ProDGnet* interface contact us at: info@prodgsystems.com or consult your authorized Pro DG Systems distributor.

ProDGnet interface

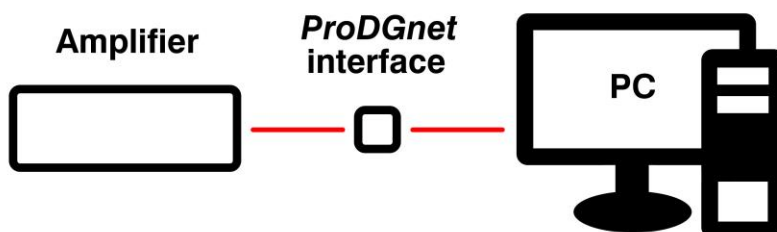

Below is a **guide for use** and information on the different menus of the *ProDGnet software*, which we can see **when we connect the DSP module of the unit to the PC**, through the ProDGnet interface:

Once the software is downloaded on your PC; create your network of Pro DG Systems systems, to do this connect the Ethernet cabling to the different units;

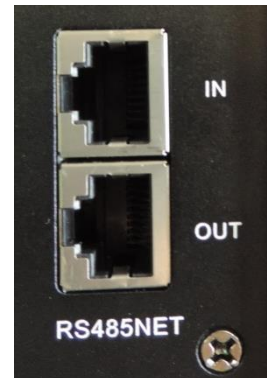

When you start the software, the **general menu** will be displayed by default. (OVERVIEW);

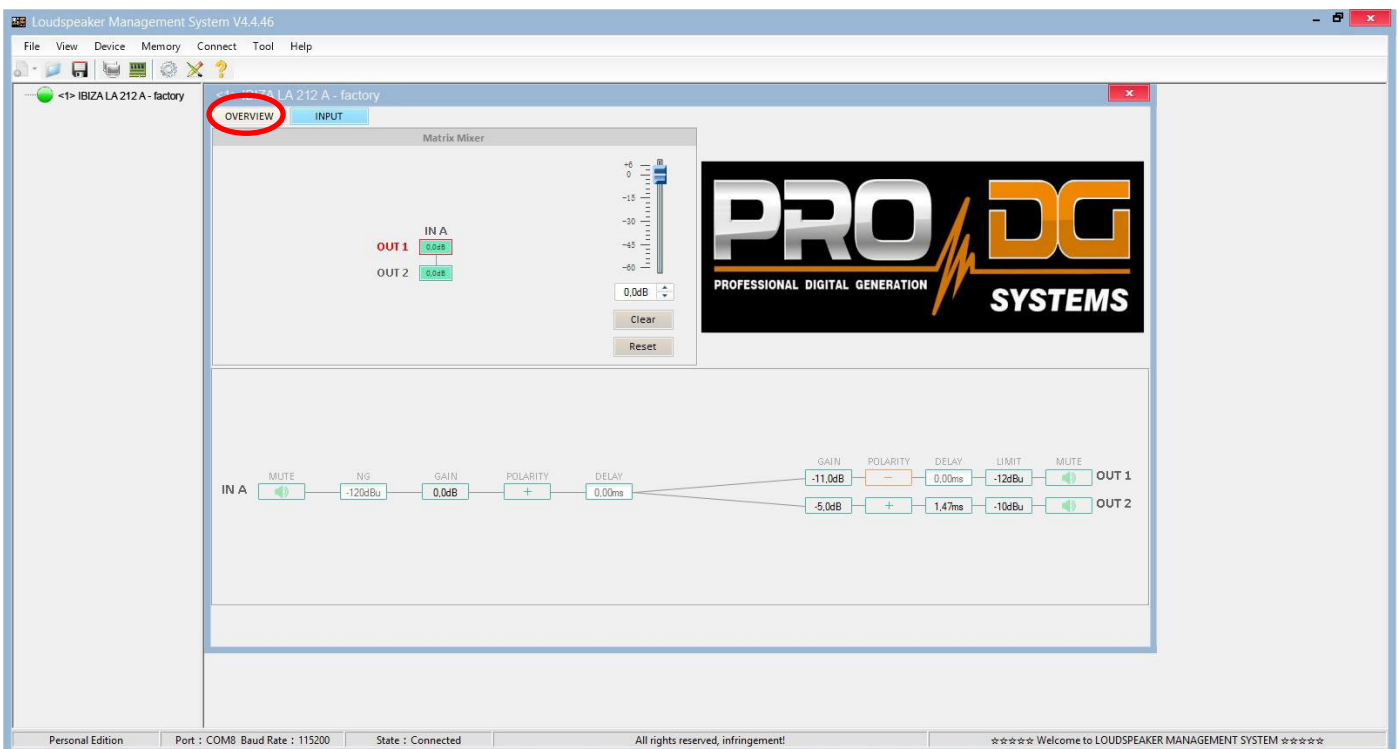

This menu allows modifying different options on input A and outputs 1 and 2, such as: Mute, Limiter, Gain, Polarity and Delay.

When clicking “**Connect**” > “**Remote mode**”, in the top bar;

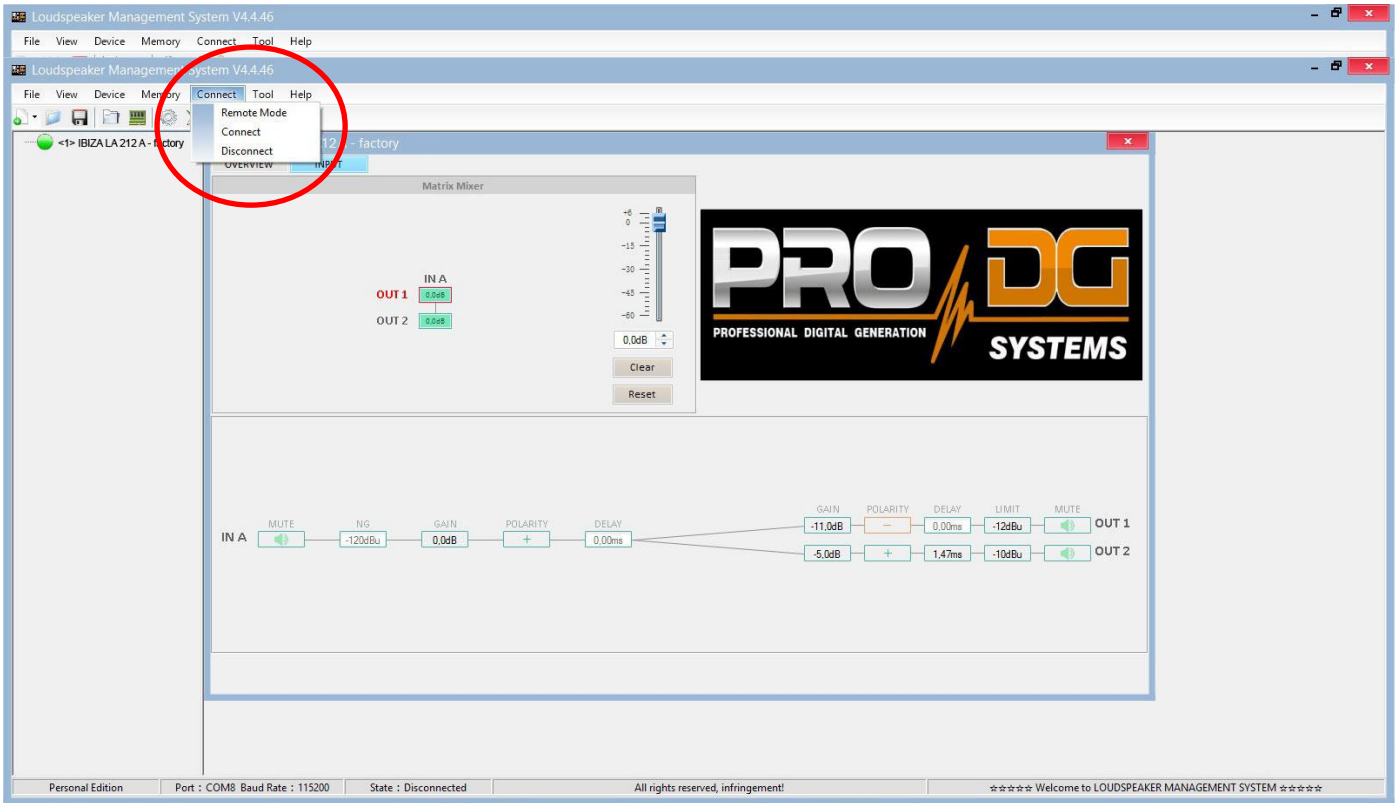

The following dialog box will appear;

Allowing connection to the DSP module of each unit connected to the Ethernet network.



After pressing “OK” all connected units will be displayed (in green) to the left of the menu;

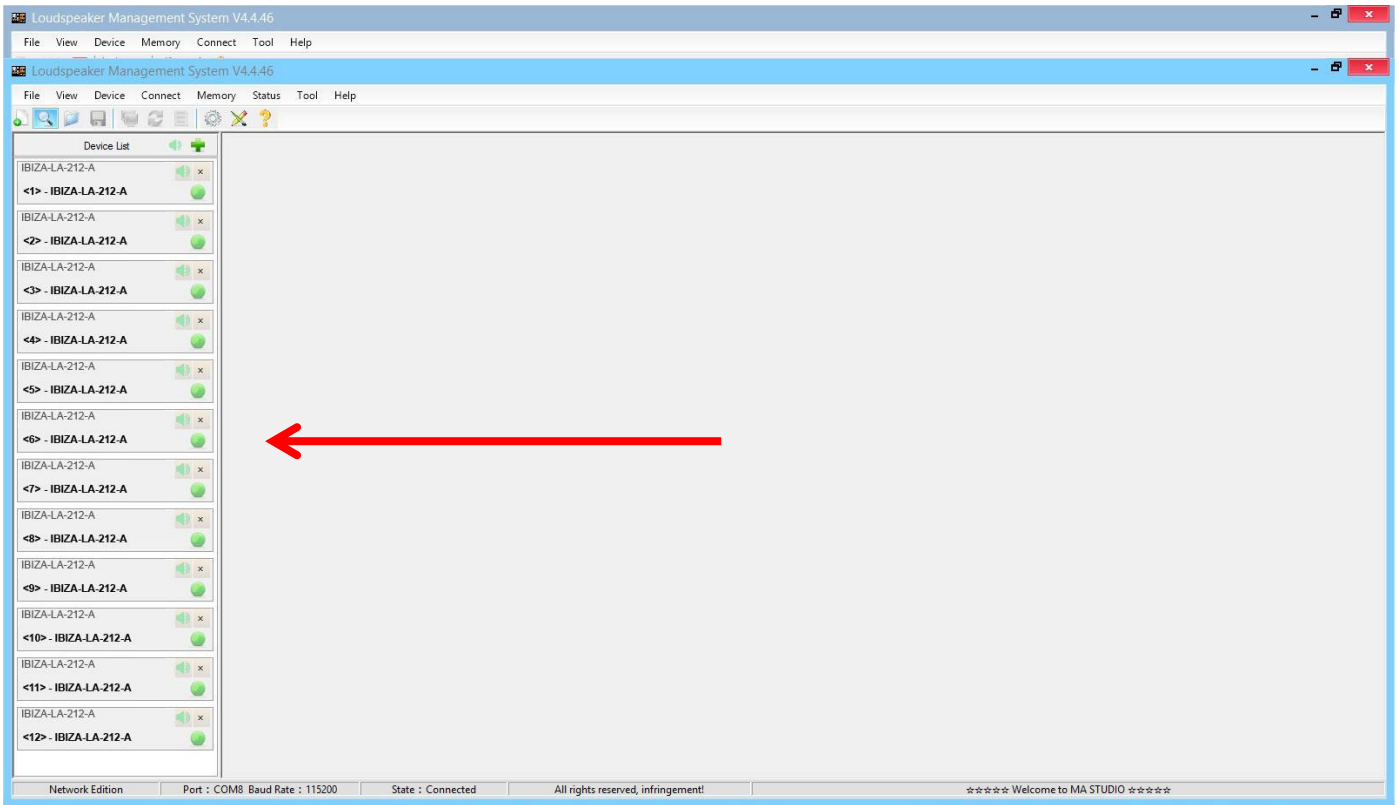

By clicking on the **INPUT** menu, a 31-band parametric equalizer is displayed, allowing you to select the type of Filter, Frequency, Bandwidth (Q), Gain and Bypass;

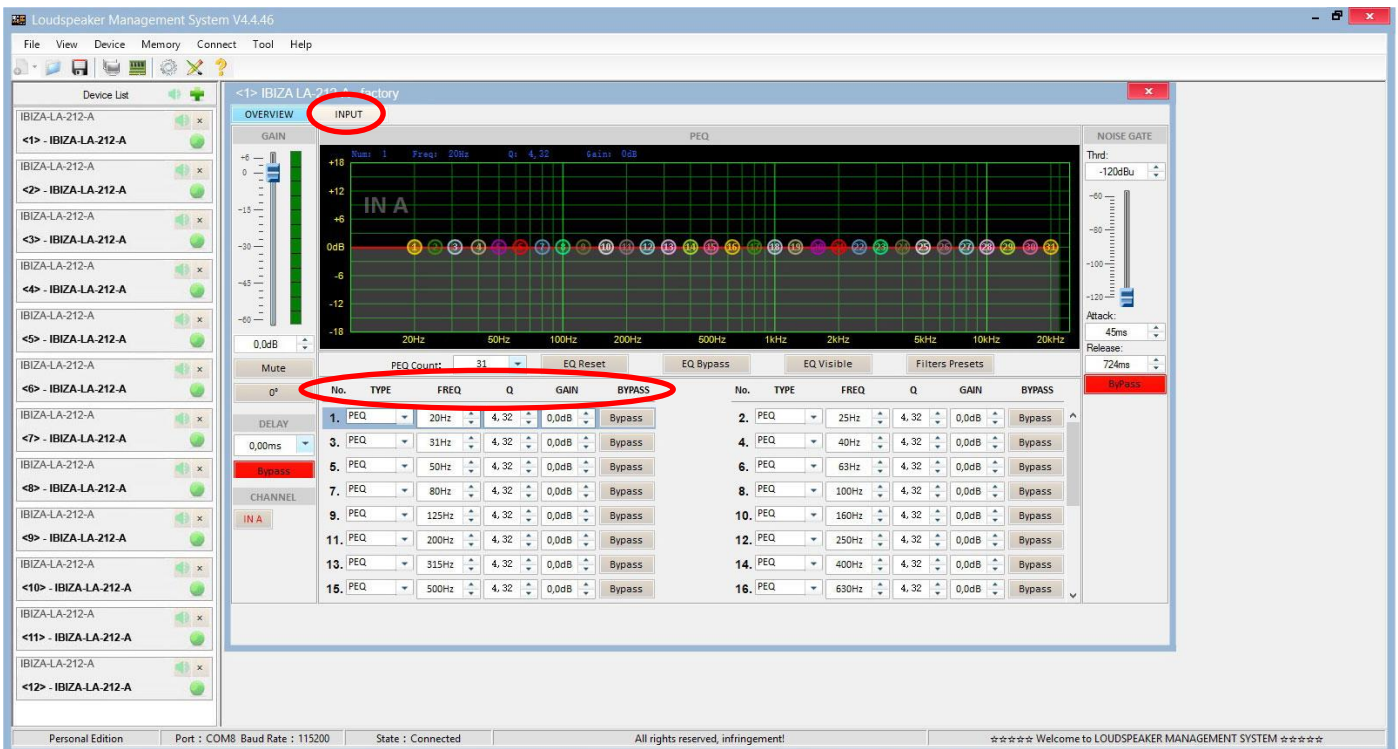

On the left of the menu, you can manually modify Gain, Mute, Delay, Bypass and input channel selection.

To the right of the menu is a noise gate where we find Threshold, Attack, Release and a Bypass of the input noise gate.

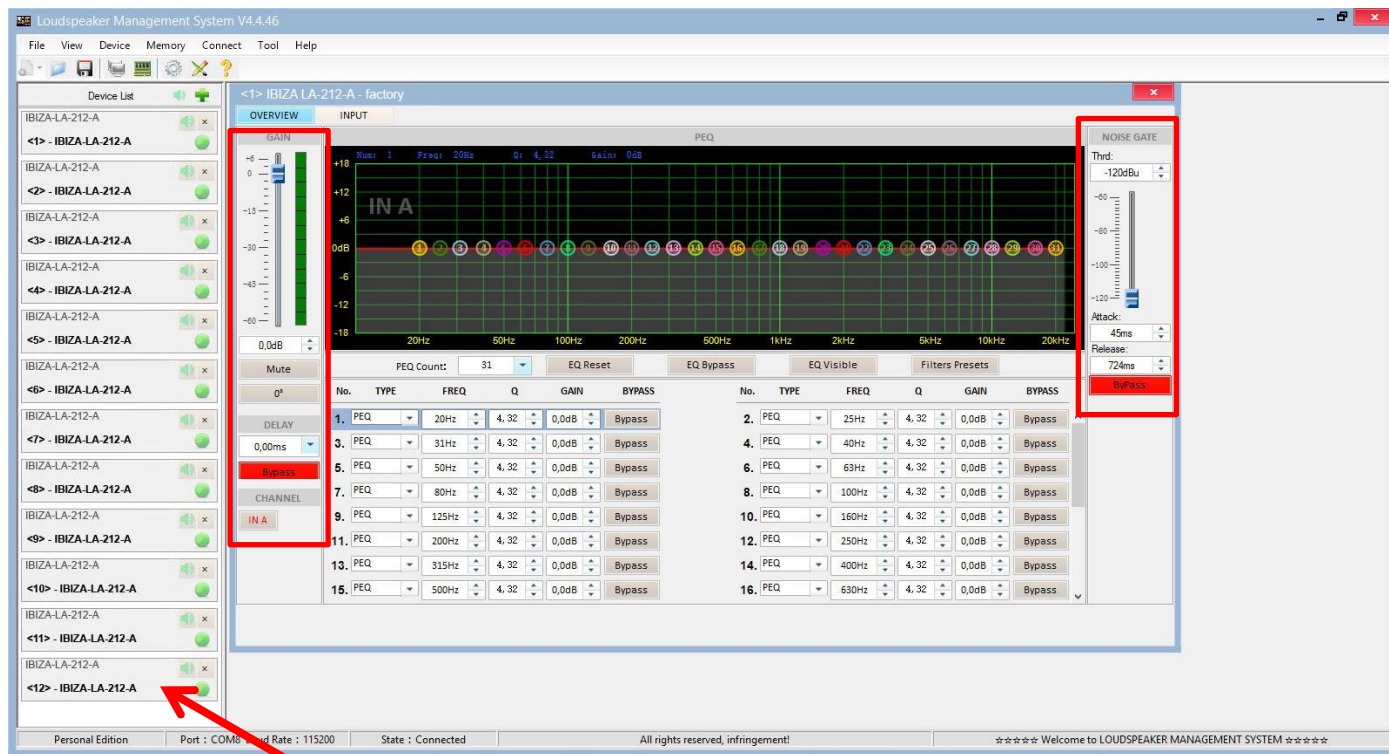

To apply changes to any of the units connected to the *ProDGnet* network, simply click on the desired unit.

To select factory stored presets, it will be necessary to click “Memory” > “Preset manager”.

The unit has 6 factory presets.

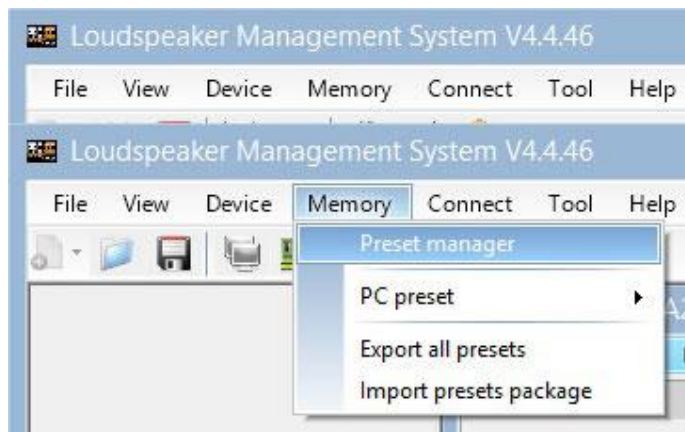

Then, the factory stored preset selection menu will be displayed;

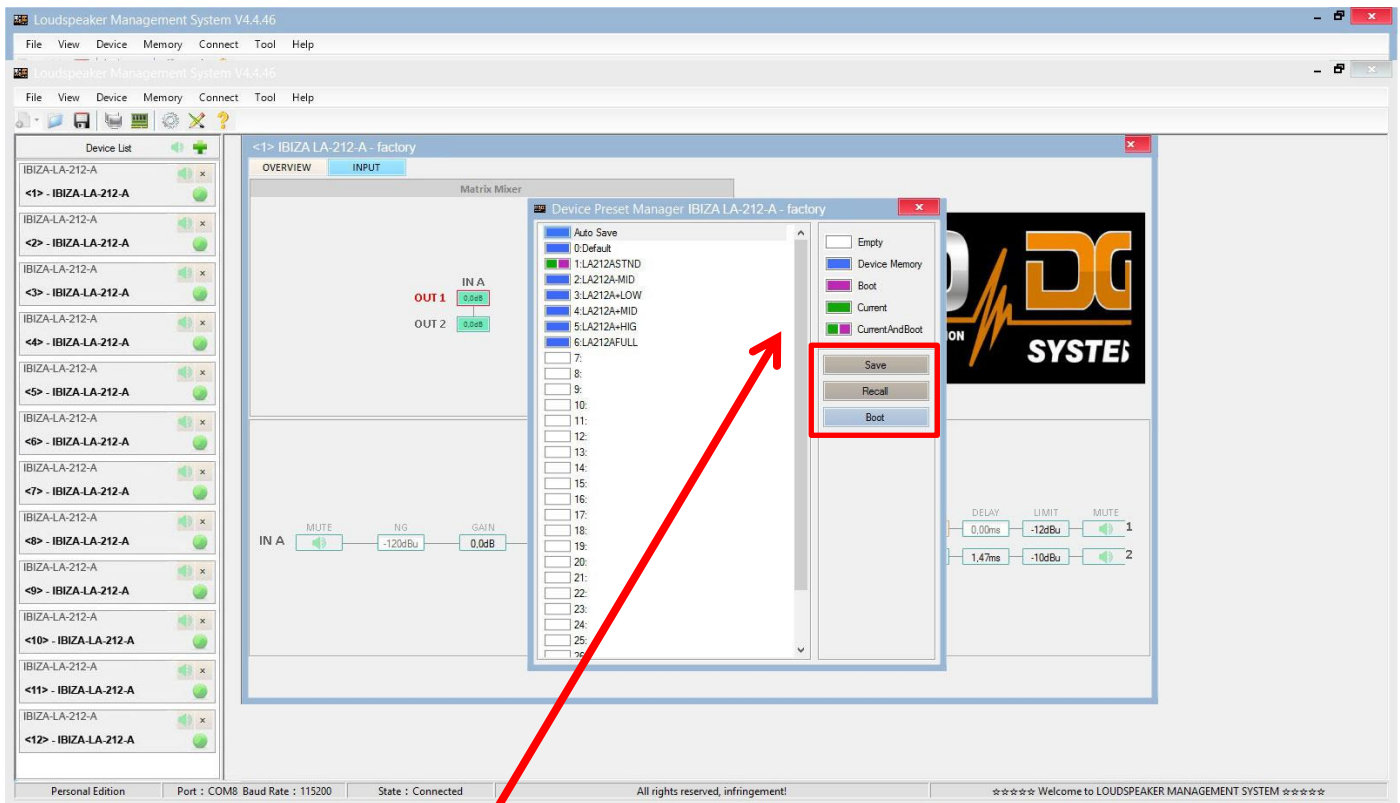

The meaning of the colors shown next to each preset is as follows:

- Empty preset.
- Preset stored in memory.
- Preset that we want to appear by default when turning on the unit.
- Currently selected preset.
- Preset currently selected and that will appear by default when turning on the unit.

“**Save**” allows saving changes made to the selected preset.

“**Recall**” allows reloading a stored preset.

“**Boot**” allows setting the selected preset as the desired preset that will appear by default when turning on the unit.

To Import or Export presets individually (preset by preset), from PC to amplifier unit or vice versa, it will necessary to click “Memory” > “PC preset”.

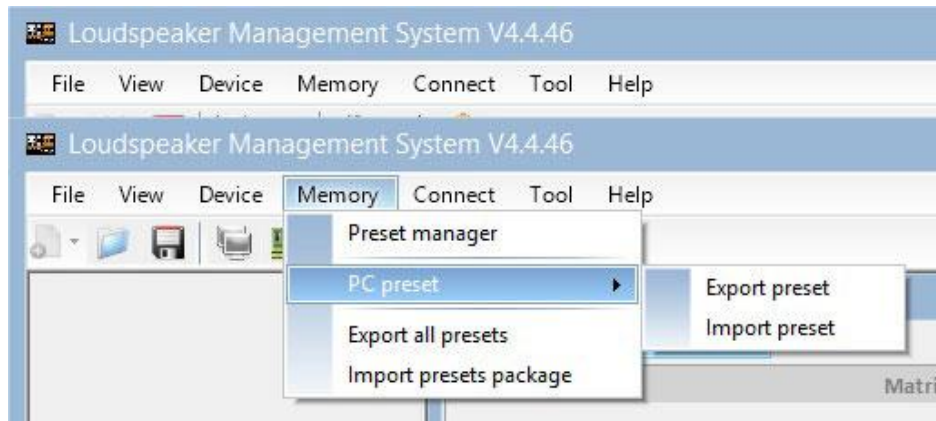

The “Export all presets” tab allows **exporting all the presets stored on the PC to the unit.**

The “Import presets package” tab allows **importing all the presets stored on the unit to the PC.**

To change the language, click “Tool” > “Language”.

If you want to **change the menu color**, click “Tools” > “System Color”.

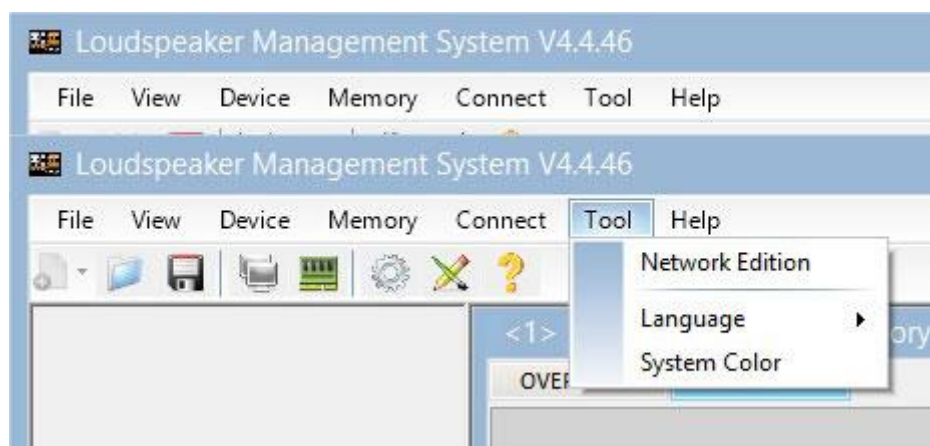

By having a network of systems connected to each other through Ethernet cabling and RS485 protocol, you have the possibility of **creating a group of systems**, which allows any change or equalization made to be applied to all the units that are part of the same network.

For example, if we have twelve units IBIZA LA 212 A, when creating a group made up of these units, any change or equalization made will be applied to all units;

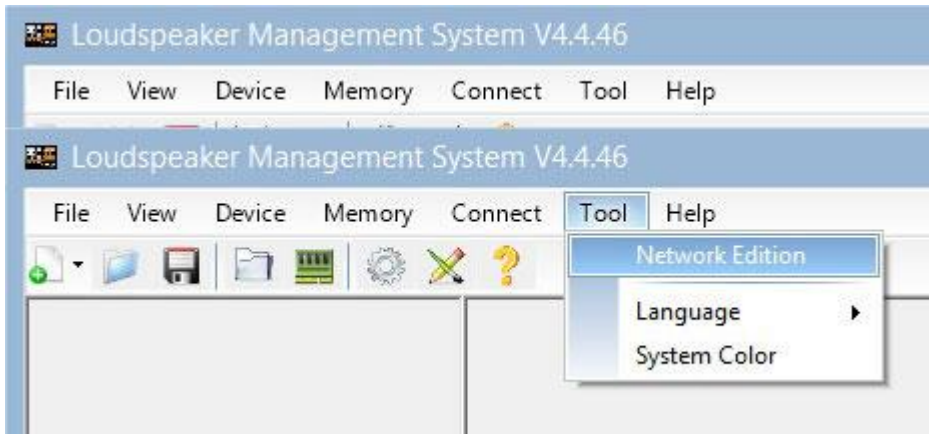

To create a system group, click “Tool” > “Network Edition”

Then click on the **magnifying glass** icon;

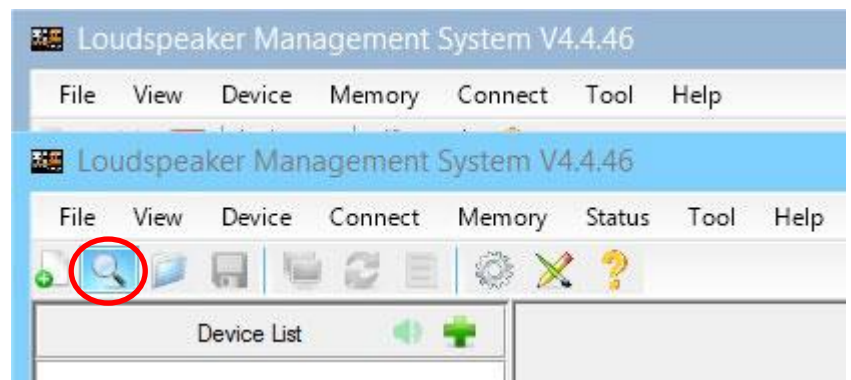

The following dialog box will appear. Click “OK” button.



Once the previous step has been completed, all the units connected to the network will be displayed on the left of the menu (the group has not been created yet). Then click “**Device List**” button.

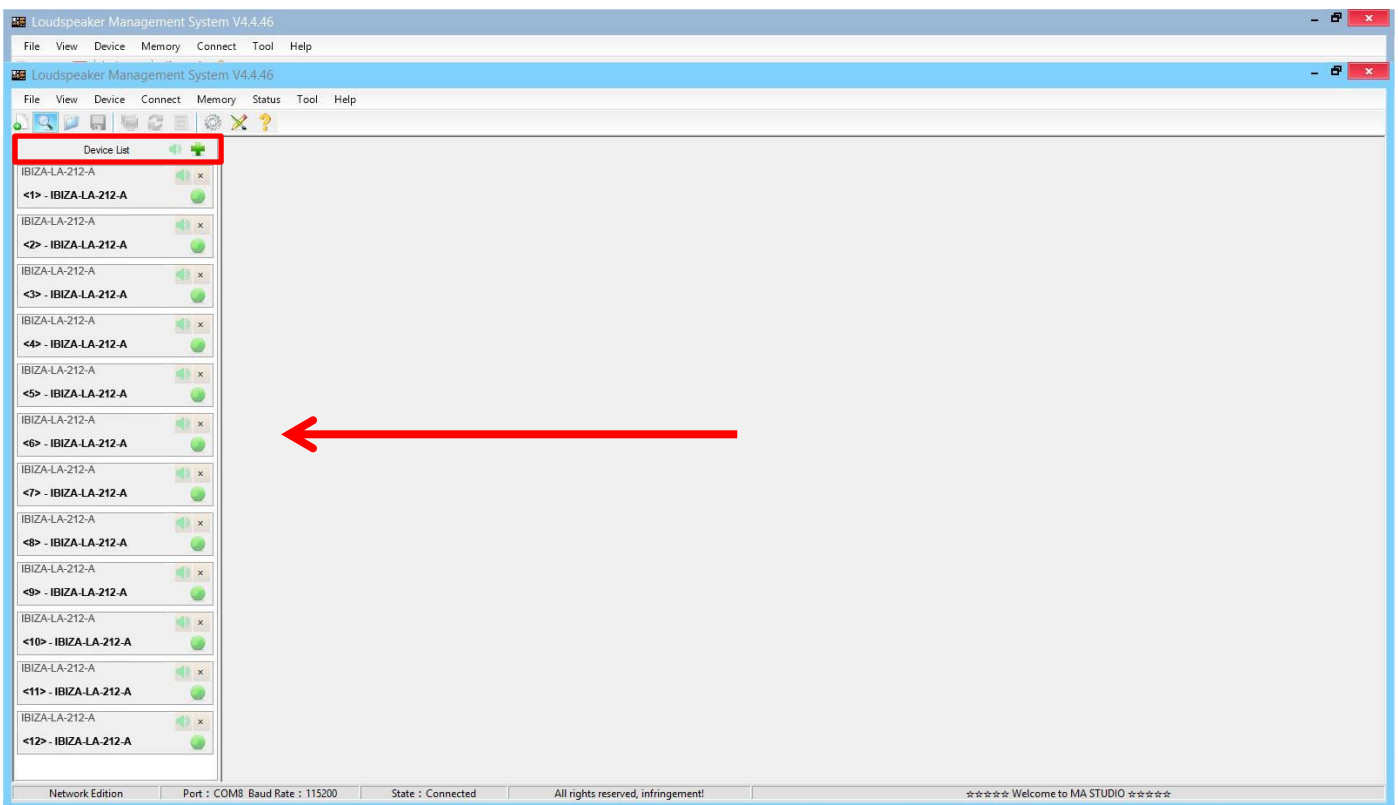

The following dialog box will appear;

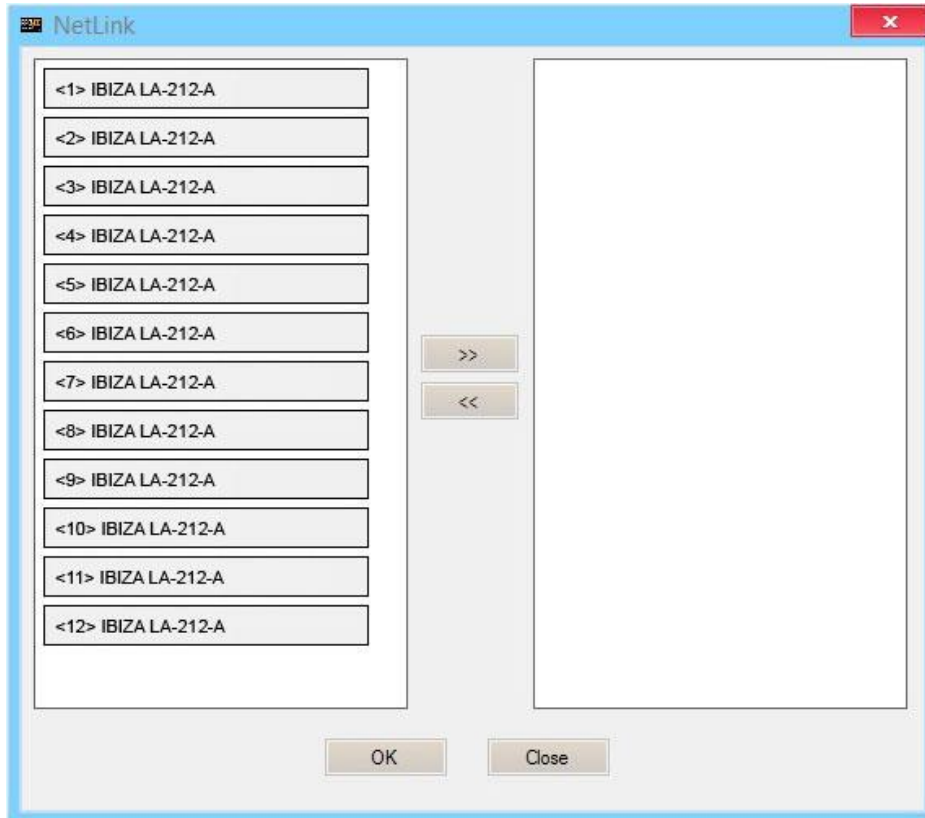

Next, we will select all the units that will be part of the group and click on the right arrow icon, the units that are displayed in the box on the right are the ones that will be part of the same group;

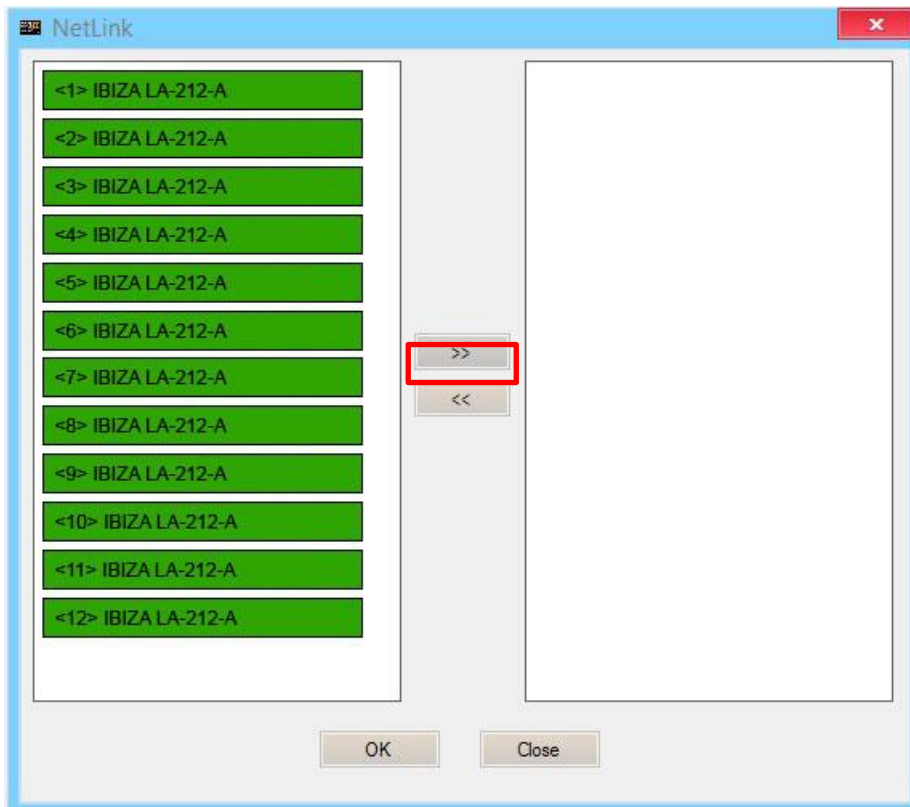

We will press “OK” button, which will cause the following dialog box to appear, in which we can modify the name of the created group, as well as different parameters of it;

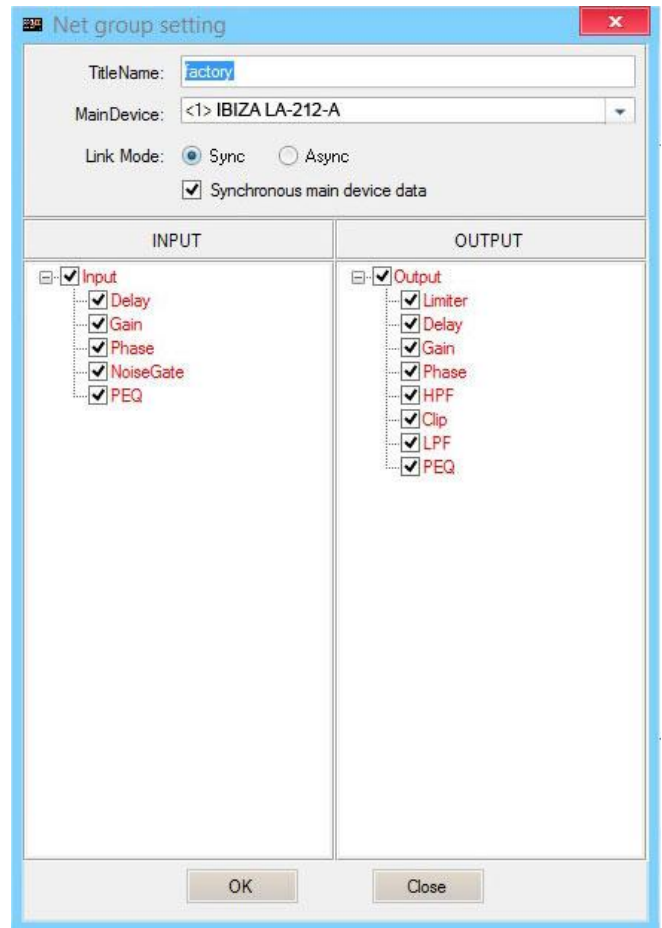

By pressing “OK” button in the previous step, the group creation process will be completed. In the menu on the left we can see that all the selected units are already part of the same group.

DSP. Selecting presets in the unit itself

It is possible to select stored presets in the DSP unit, directly from the IBIZA LA 212 A amplifier. To do this, follow the following steps:

1. Connect the system to the mains and put the switch button in ON position.



2. Once the main menu is displayed on the LCD screen, we will proceed to unlock the unit, to do this, press the preset selection button for a few seconds;



Until the password menu appears;



Important: request the password to Pro DG Systems technical support department via email at: sat@prodgsystems.com or to your authorized Pro DG Systems distributor.

3. Enter the password and turn the preset selector knob clockwise to press "OK" (without holding, just click);

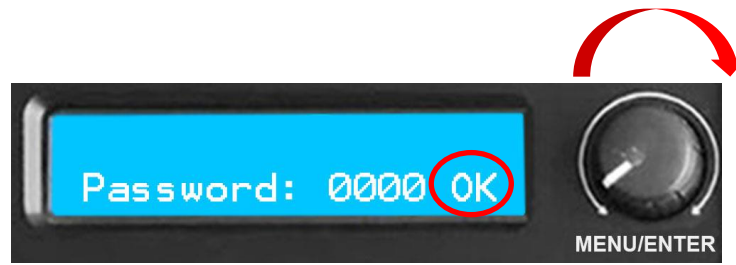

Once this step is completed, the main menu at the beginning will be displayed again. If everything has been done correctly, the “padlock” (screen lock) icon will no longer be displayed in the main menu;



4. After completing step 3; press the preset selection button two times without holding it (just double click), this will cause the preset selection menu to appear;



You can now navigate between the different presets stored in the unit and select the one you want by pressing the button. By default, the unit has 6 factory presets.



The factory presets have been developed based on the feedback received from professionals working with our systems around the world, taking into account the acoustic preferences on each continent and, as a summary, the factory presets included for IBIZA LA 212 A are the following:

- Preset nº1: **EUR1**; preset based on the acoustic preferences of the European continent. It is characterized by offering the maximum possible balance between the different ways, with a slight boost in MF and HF, ideal for playing live music.
- Preset nº2: **EUR2**; same concept as EUR1 but with greater attenuation in HF. Ideal for playing live music where a less energetic preset is required.
- Preset nº3: **USA1**; preset based on the acoustic preferences of the American continent. It is characterized by being the most energetic preset among all those included in the unit, with greater boost in MF and HF.
- Preset nº4: **USA2**; same concept as USA1 but with greater attenuation in MF and HF.
- Preset nº5: **CHN1**; preset based on the acoustic preferences of the Asian continent, with greater attenuation in MF and HF compared to the previous presets. This preset is intended to prevent acoustic fatigue when the audience listens to the system at high volume for a long time.
- Preset nº6: **CHN2**; same concept as CHN1 but with greater attenuation in MF and HF. This is the preset with the greatest attenuation in MF and HF of all those included in the unit.

* The order of the presets that appears by default in the unit may vary depending on the region where the system is supplied, maintaining the characteristics mentioned for each preset.

The user of the system is free to choose the preset that best suits the acoustic needs of the event.



If you have any technical problem or questions about Pro DG Systems products; contact our technical support department at: sat@prodgsystems.com

Flight hardware. Safety instructions



Before flying the system, it is mandatory to take into account the following safety instructions:

- Always carry out a visual and functional inspection of the various components before use. In case of doubt about the correct functioning and safety of the components, they must be removed from use immediately.
- The fly bar for IBIZA LA 212 A (reference: FB LA 212) is designed to support up to a maximum of sixteen units IBIZA LA 212 A. In no case should the aforementioned number of units be exceeded.
- In case of using the system in stacked format on a subwoofer; the maximum number of stackable units allowed will be 6 units. Always secure the array to the subwoofer by using slings.
- The hanging of the units must be carried out by professionals with adequate knowledge of the components and hardware to be used. This process must be carried out by at least two people.
- It is the responsibility of the person or team installing the system to ensure that the suspension / fixing points are suitable for the intended use.
- The application of safety factors of 5:1 for enclosures and static parts is accepted in a standardized manner. For those elements subjected to fatigue due to friction and variations in the stresses to which they are subjected, the following safety factors must be met: 5:1 for steel cable slings, 4:1 for steel chain slings and 7:1 for polyester slings. This means that an element with a breaking stress of 1000 Kg can be subjected to a static working load of 200 Kg (safety factor 5:1) and a dynamic load of only 142 Kg (safety factor 7:1).
- When hanging a system, the working load must be less than the strength of each individual anchor point as well as each enclosure.
- When suspending elements from the ceiling or other structures, extreme caution must be taken by previously calculating their resistance. Sound systems should never be hung on structures that do not guarantee full safety guarantees.
- When hoists are in operation (when lifting the system), ensure that no one is directly under or near the load.
- Under no circumstances scale or hang to the array.



- It will be necessary to fix at different points those systems that are subject to gusts of wind, to avoid their swaying. In no case is it recommended to fly systems that are subject to strong gusts of wind.
- No risk should be accepted in terms of public safety. It is the responsibility of the person or team of people carrying out the assembly to provide themselves with personal safety elements, such as helmet, gloves, safety footwear, etc., to carry out this work. As well as the correct signage of the space in which work is being done.
- All accessories used to fly a Pro DG Systems sound system not provided by Pro DG Systems are the responsibility of the user(s).

In no case will Pro DG Systems be responsible for damages caused by incorrect use of the flying system by the user or users, whether physical damage to people or damage to the product or the attached facilities. As well as for failure to comply with the previously indicated safety instructions.

Flight hardware. Components

At Pro DG Systems we know the importance for the professional of installing the different systems in a simple, fast and safe way. IBIZA LA 212 A flight system has been designed to guarantee these purposes. The different components are detailed below:

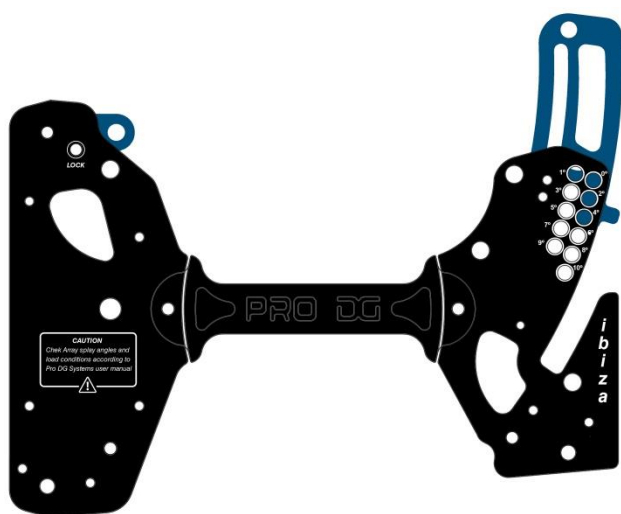

Hardware

Integrated into the box chassis itself.

Include retractable cams, their release and fixation are carried out by extracting / inserting the pins in the different points housed for this purpose.

The rear hardware has different points that allow individual angulation of each box. By default, each box is served placed at the "0" point (zero angle degree).

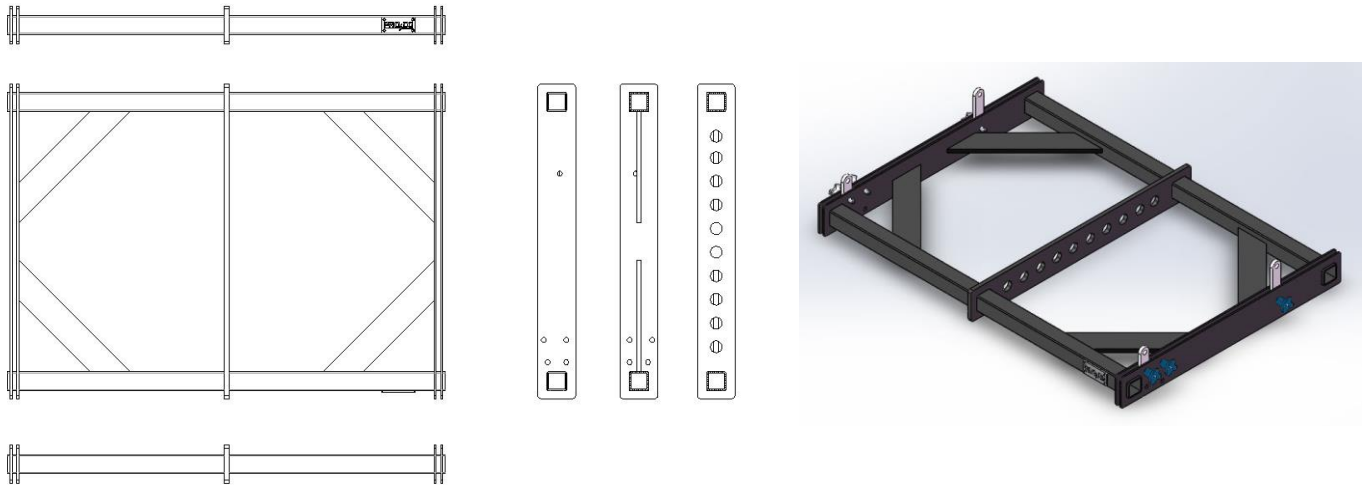

FB LA 212

Made of high-strength steel with oven-dried black electrostatic powder paint finish.

It allows the raise up of a maximum of sixteen units IBIZA LA 212 A. It also serves as a fixing base to use the system in stacked format on subwoofers.

Measures (height x width x depth):: 80 x 926 x 665 mm (3,15 x 36,46 x 26,18 in)

Weight: 30 Kg (66,14 lbs)

Fixation of the fly bar to the box.

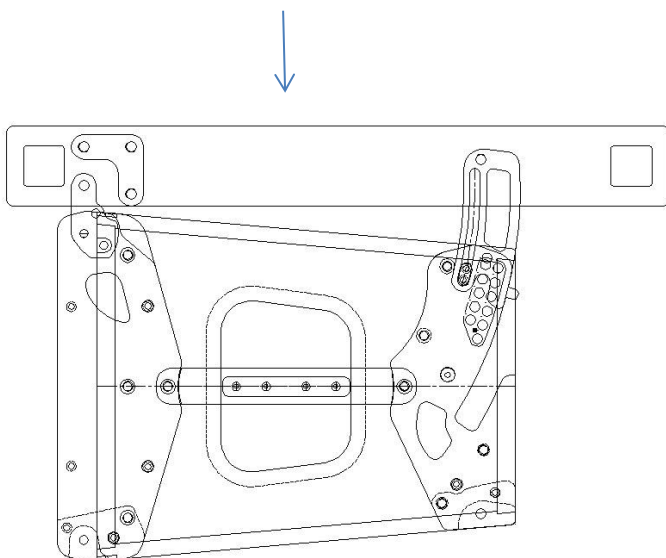

Fly bar fixation to use in stacked format.

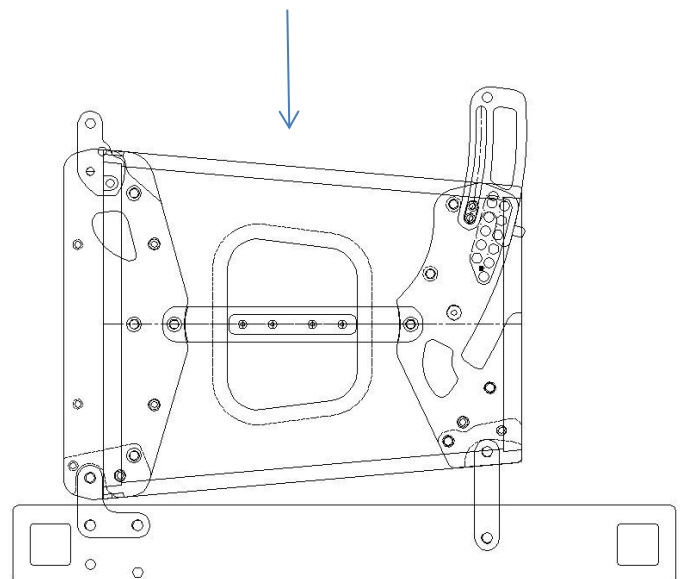



FB LA 210 + LA 212

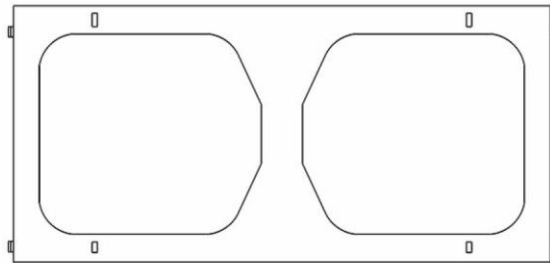

FB LA 210 + LA 212

Made of high-strength steel with oven-dried black electrostatic powder paint finish.

Allows the combination of IBIZA LA 210 A and IBIZA LA 212 A Line Array systems. It allows the raise up of a maximum of sixteen units between both systems (example; eight units IBIZA LA 210 A + eight units IBIZA LA 212 A).

Measures (height x width x depth): 50 x 905 x 500 mm (3,15 x 35,63 x 19,69 in).

Weight: 20 Kg (44,09 lbs).

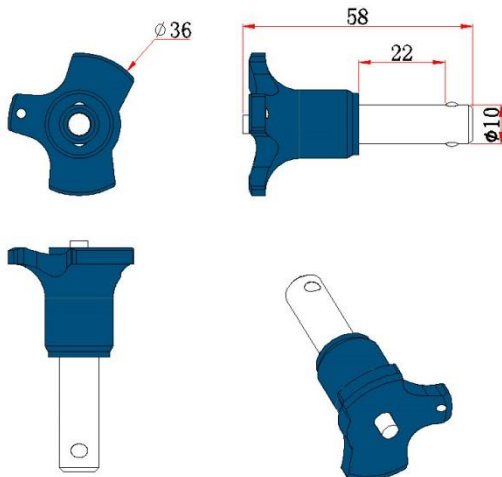

Pin locks

They allow the attachment of the box to the different components, as well as the combination between several boxes to form the array.

They have a safety extraction/insertion system through the use of a locking button.

Note: the specifications of these components may be changed without prior notice. To be aware of the latest modifications, please consult Pro DG Systems website periodically.

How to fly the system up

Important: before flying the system, carefully read the subsection “Safety instructions”, located in the “Flight hardware” section (pages 35 - 36).

- 1 Remove the locking pins located on the front and rear hardware to release the cams.



- 2 Pull the cams up and secure them again using the pins. On the rear hardware; set the cam at the desired graduation, the point “0” represents a zero degree of angulation.



3 Install the fly bar to the box using the fixation pin locks.

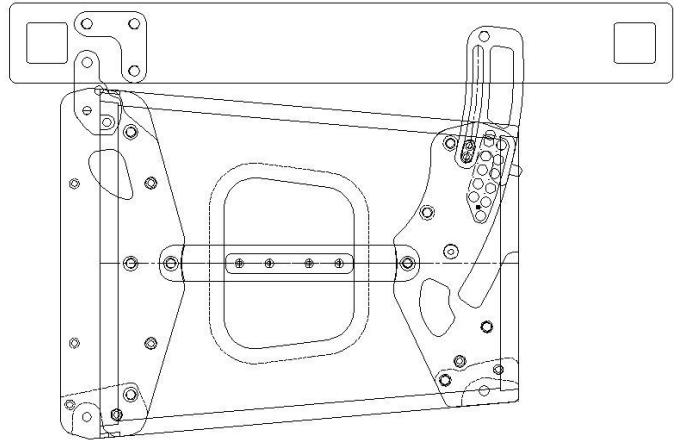

4 Then repeat step 2 for the following boxes fixation.

The design of the cams included in the rear hardware prevents uncontrolled swinging when disassembling the last box of the array assembly.



Note: use TR LA 212 transport trolley to facilitate lifting the system from the ground; stacking the boxes on the trolley first and installing the fly bar last.

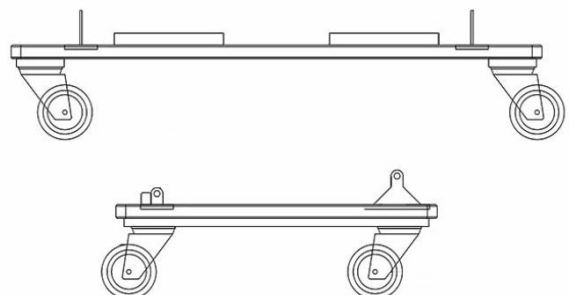
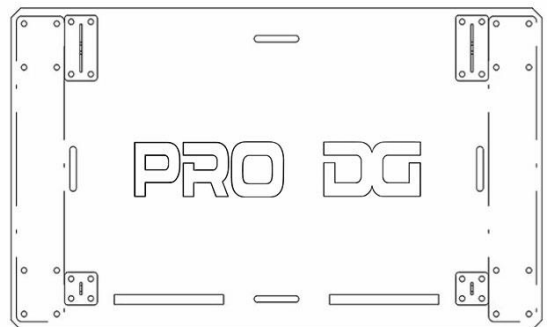

Stack mode usage

By using the cams built into the fly bar FB LA 212;

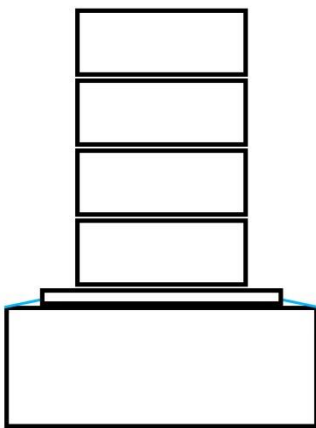
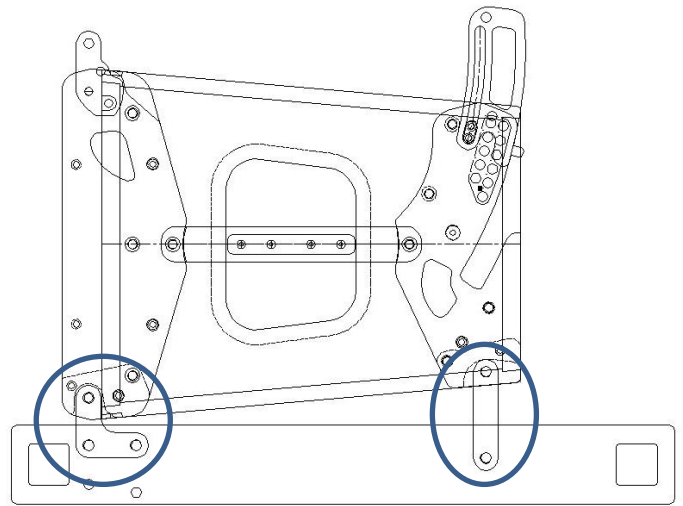

Slings

If the array is stacked on a subwoofer, it will be necessary to secure it by using slings. In any case, it is not recommended to stack more than 6 IBIZA LA 212 A units.

By using TR LA 212 transport trolley. Simply placing the stacked box assembly on the skid above the subwoofer **(1)**. Once located; it will be necessary to press the brake pedals of the trolley **(2)**, as well as securing the array to the subwoofer by using slings **(3)**

In any case, it is not recommended to stack more than 6 IBIZA LA 212 A units.

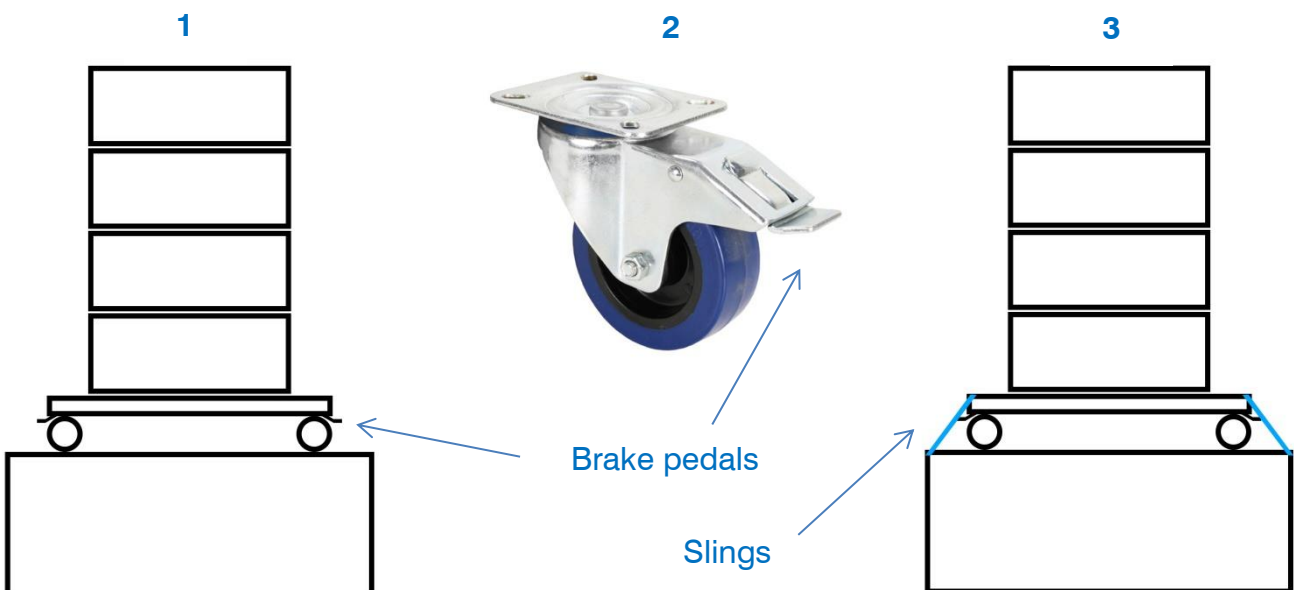

Ease Focus prediction software

At Pro DG Systems we know that manufacturing high-quality speakers is an important part of the job. The guarantee of being able to use the systems properly is the other fundamental part of our work. Good tools make the difference to achieve optimal use of systems

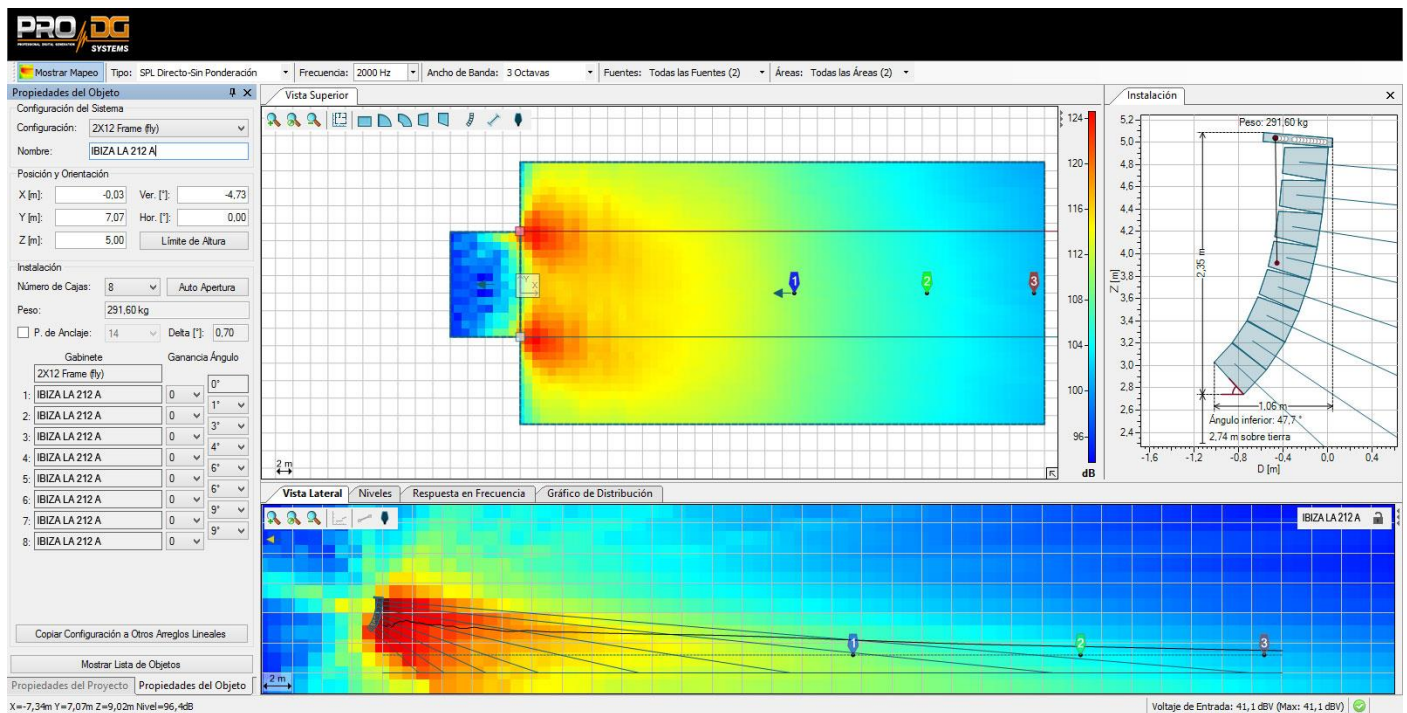

IBIZA LA 212 A has Ease Focus V3 prediction software with which we can simulate the behavior of different systems in different places and circumstances, as well as obtain information on coverage, frequency, SPL and general behavior of the system, in a simple and comfortable way for the user. It is very easy to use and we have training courses for users of Pro DG Systems products. For more information, consult our technical service at: sat@prodgsystems.com

Ease Focus prediction software can be downloaded directly at Pro DG Systems website: <https://prodgsystems.com/19-scrpt-software.html>

You can download the user guide of Ease Focus 3 software [here](#)

You will find GLL files to simulate the behavior of IBIZA LA 212 A at: www.prodgsystems.com

Accessories

TR LA 212

Transport trolley for four units IBIZA LA 212 A.

It has a special polyurea finish resistant to impacts and inclement weather.

It has a brake system and slots for fixing it using slings, etc.

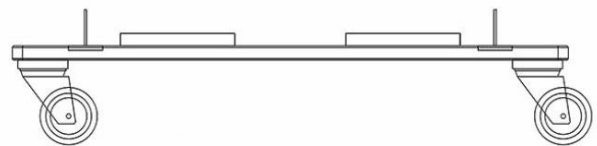
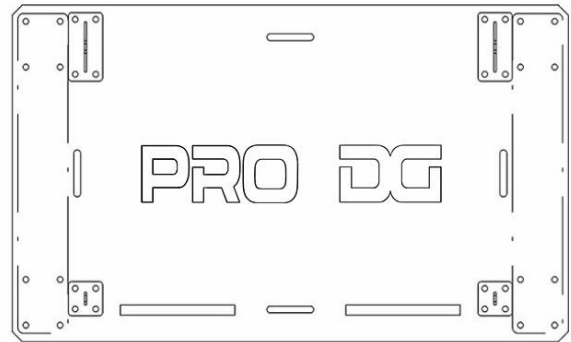

CV LA 212

Protection cover for four units IBIZA LA 212 A.

Made of waterproof material.

Complete system wiring ready to go.





IBIZA LA 212 A

PRO DG SYSTEMS INTERNATIONAL

P.I. Santa Bárbara. C/ Aceituneros nº 5.
41580 Casariche (Sevilla), Spain
Tel: +34 954 011 095
Cel: +34 678 548 947
export@prodgsystems.com
info@prodgsystems.com
www.prodgsystems.com

PRO DG SYSTEMS AMERICA

1225 NW 93rd CT
Doral, FL, 33172
Español: (786)-715-4705
English: (786) 314-1856
sales@prodgamerica.com
www.prodgamerica.com